

NF LEVELLING MACHINE MOUNTS

The N.F.-type AMC MECANOCAUCHO® mounts are used in cases where light or heavy machines should not be fixed to the floor or ground.

The height adjustment system can be used to adjust the machines to the required level, thus insulating from vibrations and reducing noise. The AMC MECANOCAUCHO® type NF comes with a tilting system allowing optimum adaptation to all surfaces.

The elastomer used is a mixture of oil-resistant synthetic Nitrile Butadiene Rubber (NBR).

Height is adjusted by means of a screw, although this operation can even be performed once the machine has been assembled. The wide contact between the base of the machine guarantees good overall stability.



INSTALLATION INSTRUCTIONS

Lift the machine and insert the mount under it.

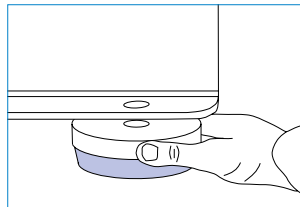

Insert and turn the screw manually until it slots into place.

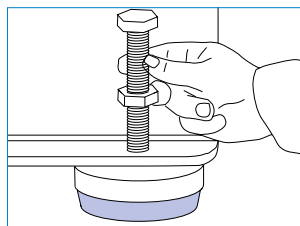

Adjust the height of the machine by turning the screw.

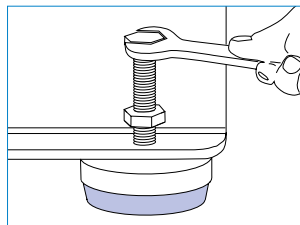

Block using the checknut.

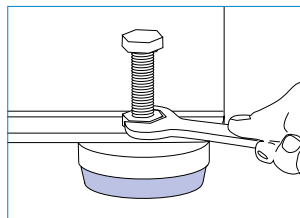

AMC MECANOCAUCHO® TYPE NF

Type	A (mm.)	C	B mm. Mín	B mm. Máx	B mm. Reglaje	H mm. Min	H mm. Máx	STATIC LOAD Nominal (Kg.)	DEFLECTION mm.	Weight (gr.)	Code
NF-65	65	M12x1,65	27	34	7	105	110	320	2	349	142001
NF-85	85	M16x2	33	46	13	114	127	650	2	732	142002
NF-100	100	M16x2	35	48	13	120	130	980	2	960	142003
NF-130	130	M20x1,5	45	58	13	130	140	2500	3	1891	142004
NF-160	160	M20x1,5	53	66	13	130	140	4000	3	3397	142005
NF-200	200	M24x1,5	55	68	13	158	176	5000	3	4958	142006
NF-250	250	M30x2	67	85	18	153	176	7000	3	8575	142007

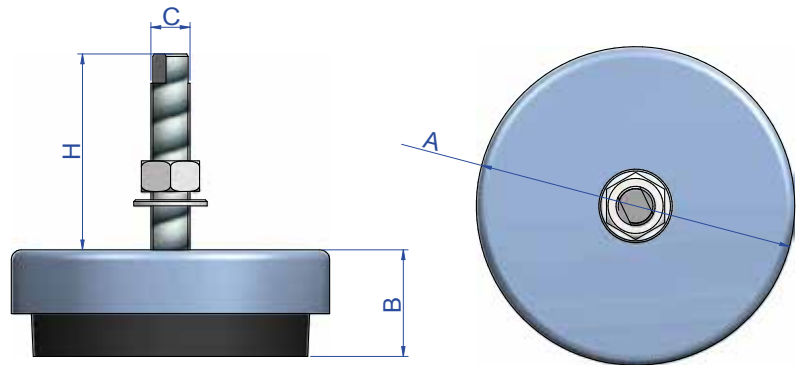
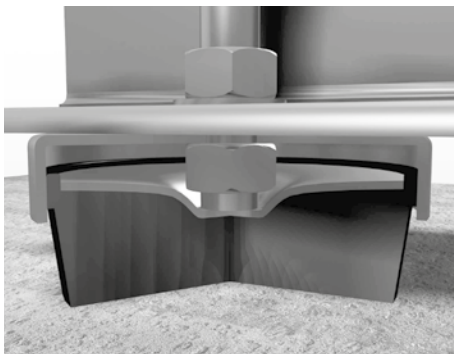

AMC MECANOCAUCHO® TYPE NFR

Type	A (mm.)	B (mm.)	C	H mm. Min	STATIC LOAD Nominal (Kg.)	DEFLECTION mm.	Code	Weight (gr.)
NFR-85	85	33	M16	100	650	2	142009	713
NFR-100	100	35	M16	100	980	2	142010	929
NFR-130	130	45	M20	130	1350	3	142011	1832
NFR-160	160	53	M20	130	2500	3	142012	3330
NFR-200	200	55	M24	140	3700	3	142013	4924

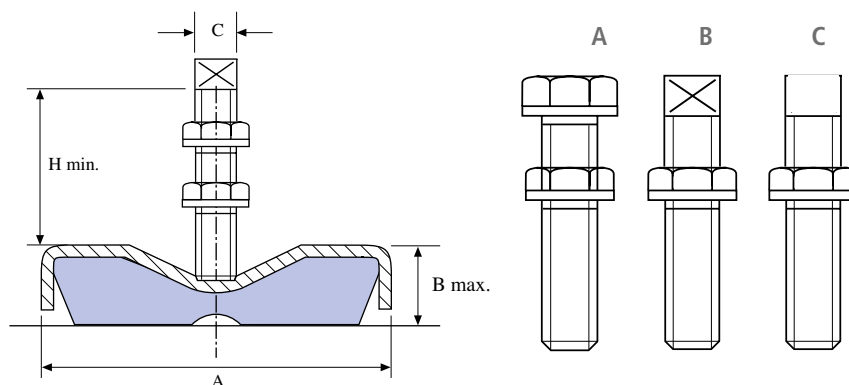

SV

APPLICATIONS

The SV-type AMC MECANOCAUCHO® mounts are used in cases where light or heavy machines are not fixed to the floor or ground. The height adjustment system can be used to adjust the machines to the required level, thus insulating areas nearby from vibrations and reducing noise.



Type	A (mm.)	B (mm.)	C	D (mm.)	LOAD MIN (Kg.)	LOAD MAX (Kg.)	Code	Weight (gr.)
000	40	23	M8	48	20	80	143001	91
00	60	28	M10	81	60	120	143002	235
0	70	32	M12	89	90	160	143003	350
1	85	32	M12	89	130	350	143004	456
2	100	40	M14	109	270	600	143005	702
3	120	37	M16	116	450	900	143006	954
4	140	55	M16	116	700	1200	143007	1513
5	160	60	M16	116	1100	1750	143008	1865
6	180	70	M24	138	1500	2500	143009	3034
7	210	75	M24	138	2100	3750	143010	4248

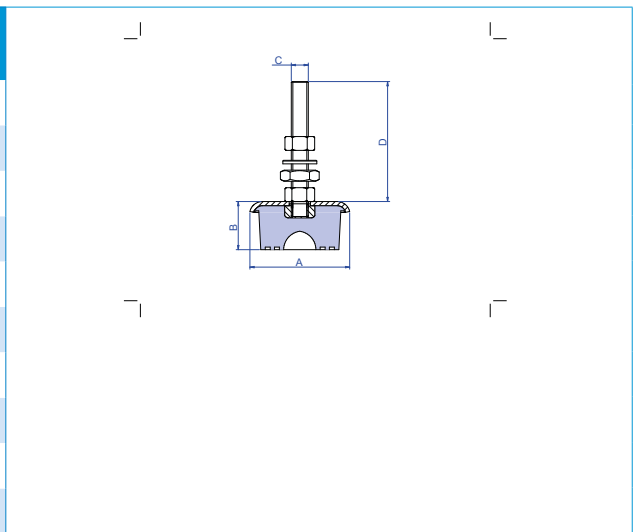

* Can be supplied in stainless steel.

AMC MECANOCAUCHO® TYPE JT

APPLICATIONS: Levelling machine mounts

Type	Code	Load (Kg.)	Weight (gr.)	Shore
JT Type	144001	25-40	53	50
	144002	75-100	53	75

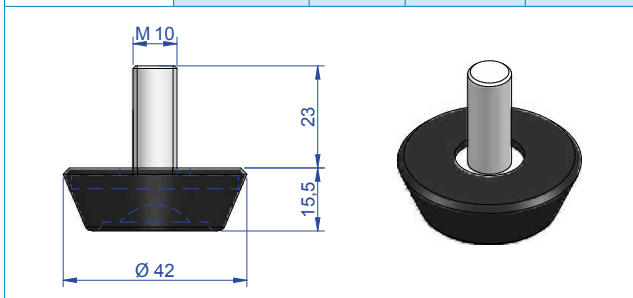

AMC MECANOCAUCHO® TYPE SX

APPLICATIONS: Levelling machine mounts

Type	Shore	Code	Load (Kg.)	Weight (gr.)
SX Type	50	145001	10-25	25

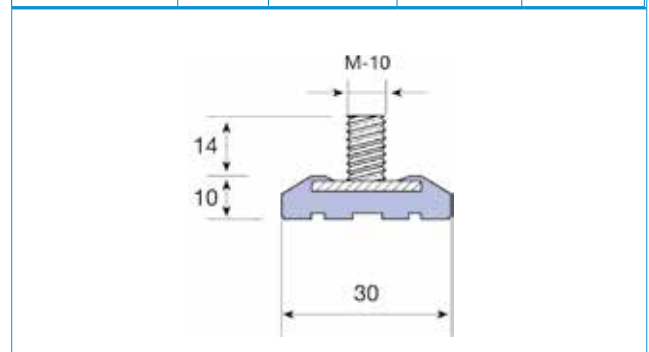

LOW SV

APPLICATIONS

The LOW SV-type AMC MECANOCAUCHO® anti vibration mounts are used in cases where light or heavy machines are not fixed to the floor or ground. The height adjustment system can be used to adjust the machines to the required level, thus insulating areas nearby from vibrations and reducing noise.



Type	A (mm.)	B (mm.)	C	D (mm.)	LOAD MIN (Kg.)	LOAD MAX (Kg.)	Code	Weight (gr.)
000 B	43	16	M8	45	40	80	147000	257
00 B	60	18	M10	81	60	120	147001	334
0 B	70	20	M12	89	90	160	147002	286
1 B	85	25	M12	89	130	350	147003	382
2 B	100	20	M14	109	270	600	147004	574
3 B	120	25	M16	116	450	900	147005	867
4 B	140	33	M16	116	700	1200	147006	1300
5 B	160	36	M16	116	1100	1750	147007	1556
00 B STAINLESS STEEL	60	18	M10	81	60	120	147014	334
0 B STAINLESS STEEL	70	20	M12	89	90	160	147013	286
1 B STAINLESS STEEL	85	25	M12	89	130	350	147012	382
2 B STAINLESS STEEL	100	20	M14	109	270	600	147015	574
3 B STAINLESS STEEL	120	25	M16	116	450	900	147011	867
4 B STAINLESS STEEL	140	33	M16	116	700	1200	147016	1300
5 B STAINLESS STEEL	160	36	M16	116	1100	1750	147017	1556

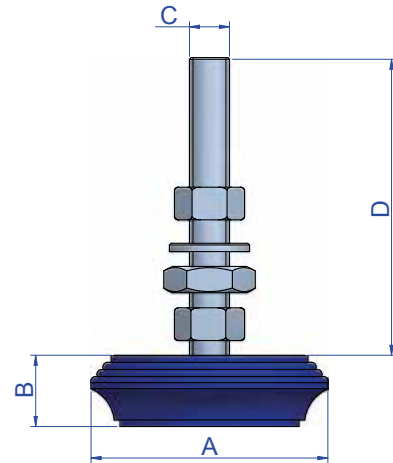

AMC MECANOCAUCHO® TYPE SM

APPLICATIONS: Levelling machine mounts.

Type	A (mm.)	B (mm.)	C	D (mm.)	LOAD MAX (Kg.)	Code	Weight (gr.)
S.M.-40	40	18	M8	48	45	146001	79
S.M.-60	65	28	M12	89	150	146002	307
S.M.-70	75	29	M12	89	250	146003	363
S.M.-90	95	30	M12	89	500	146004	573
S.M.-120	125	31	M16	116	1000	146005	904

